

# STAINLESS STEEL 90° STANDARD RADIUS ELBOWS

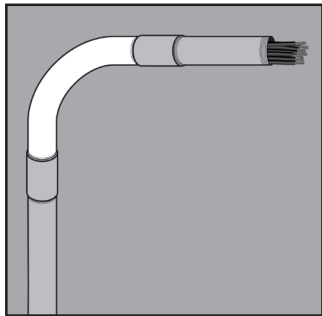

## APPLICATION

- Bent sections of rigid conduit that help in changing the direction of conduit
- Standard radius, 90°
- Threaded on both ends, NPT
- Offered in Type 316 SS and Type 304 SS
- Supplied with two thread protectors
- Manufactured in stainless steel to help prevent corrosion
- Can be installed using ordinary hand tools and require little maintenance or repair
- Provided in a bright, polished finish that does not require touch up or painting

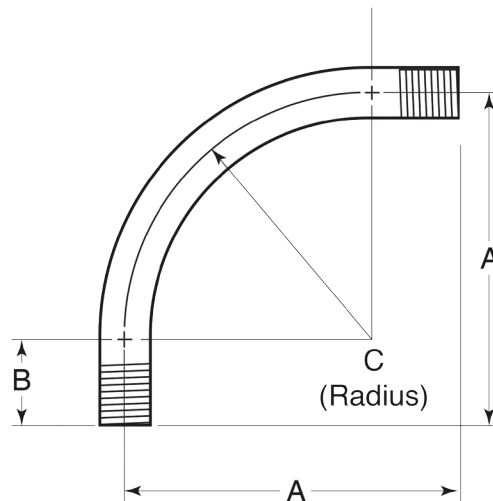

## PRODUCT DETAILS

### Material:

316 SS and 304 SS

### Standards:

ASTM A312

### Country of Origin:

Manufactured in USA

### UL File Number:

DYWV.E300683  
(Standard 6A)

### Canada UL File Number:

DYWV7.E300683  
(Standard 6A)

Part Number	Size	Weight/ Each (lbs.)	Dimension (in.)		
			Offset "A"	Straight End "B"	Centerline Radius "C"
ELB50	½ in.	1	6.50	2.12	4.00
ELB75	¾ in.	1	7.25	2.75	4.50
ELB100	1 in.	2	8.63	2.88	5.75
ELB125	1-¼ in.	3	10.75	3.25	7.50
ELB150	1-½ in.	4	11.63	3.38	8.25
ELB200	2 in.	6	13.31	3.81	9.50
ELB250	2-½ in.	13	16.50	5.75	10.50
ELB300	3 in.	19	18.75	5.75	13.00
ELB400	4 in.	31	23.18	7.96	16.00

Type 304 SS products are denoted by adding "-304SS." For example: ELB75-304SS.

